

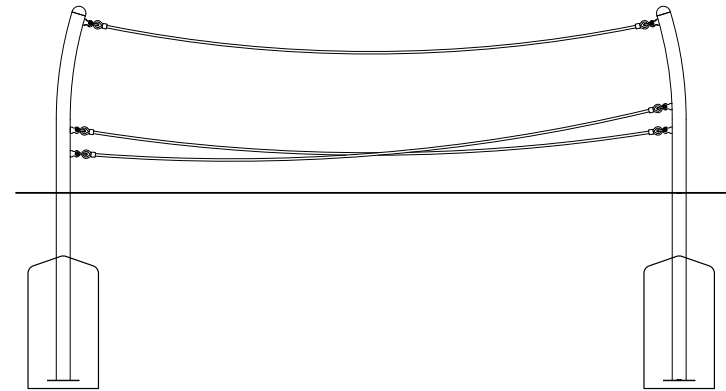

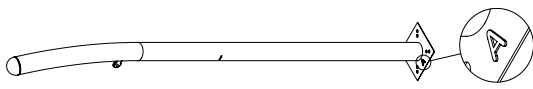



CC & BM

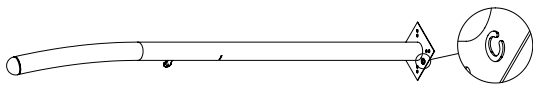
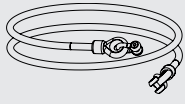
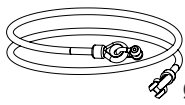

1	78603003	 2769 x 746 x 200mm	x1	26Kg
2	78603004	 2769 x 746 x 2000mm	x2	26kg
3	78603005	 2769 x 746 x 2000mm	x1	26kg
4	78805044	 Ø16 x 3612mm	x1	6Kg
5	78805060	 Ø16 x 3773mm	x2	6Kg

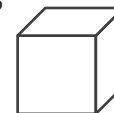
S12

 kg
 122

S15

 L x W x H (m)
 4.03 x 0.59 x 1.20

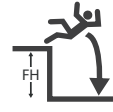
S13

 m³
 0.70

S14

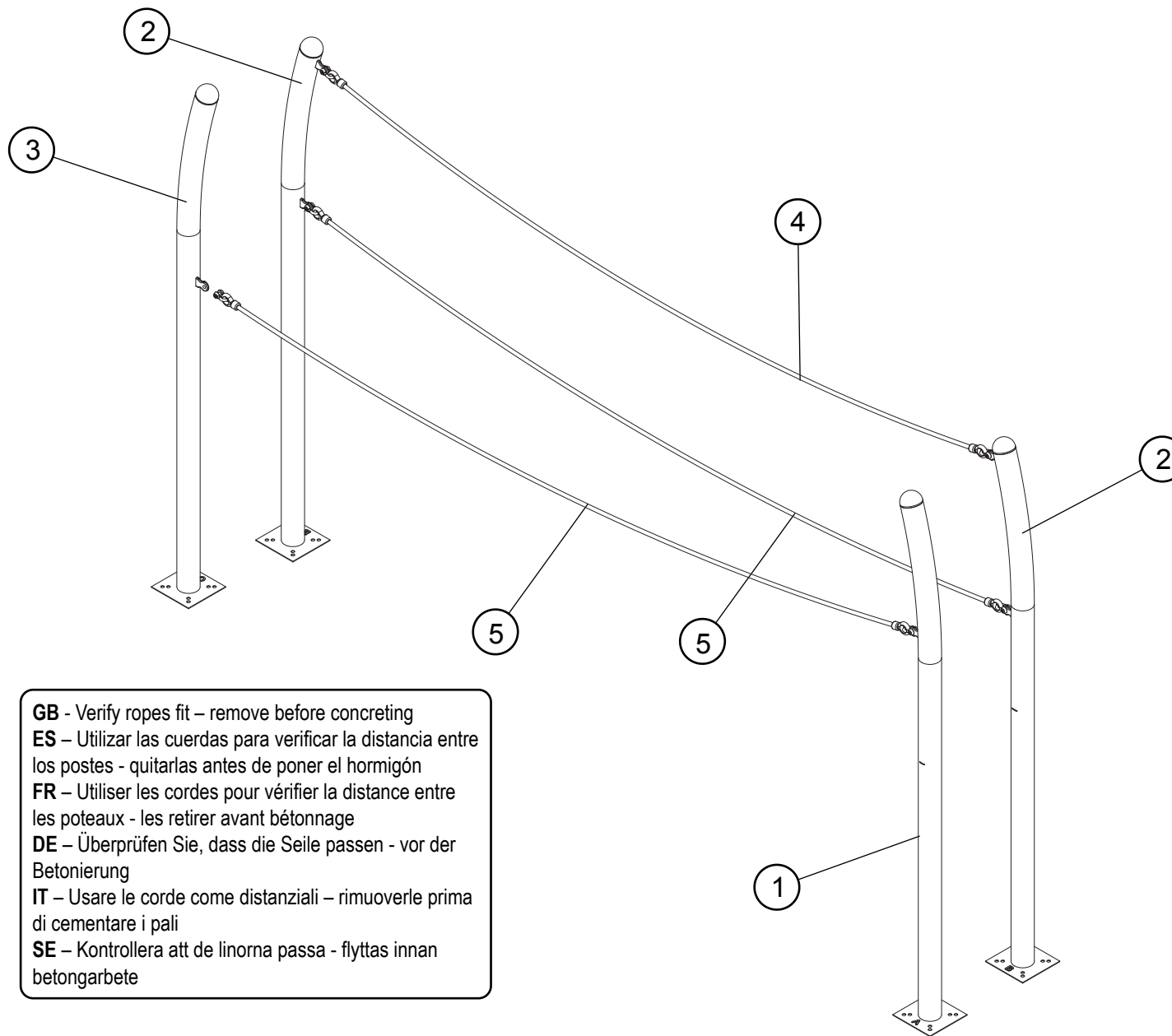
 m²
 10 x 10

S6

 EN1176
 0.6m

S20

 2 x 6



S25



S2 (50mm)
≥C20-25



7 x 24h



101

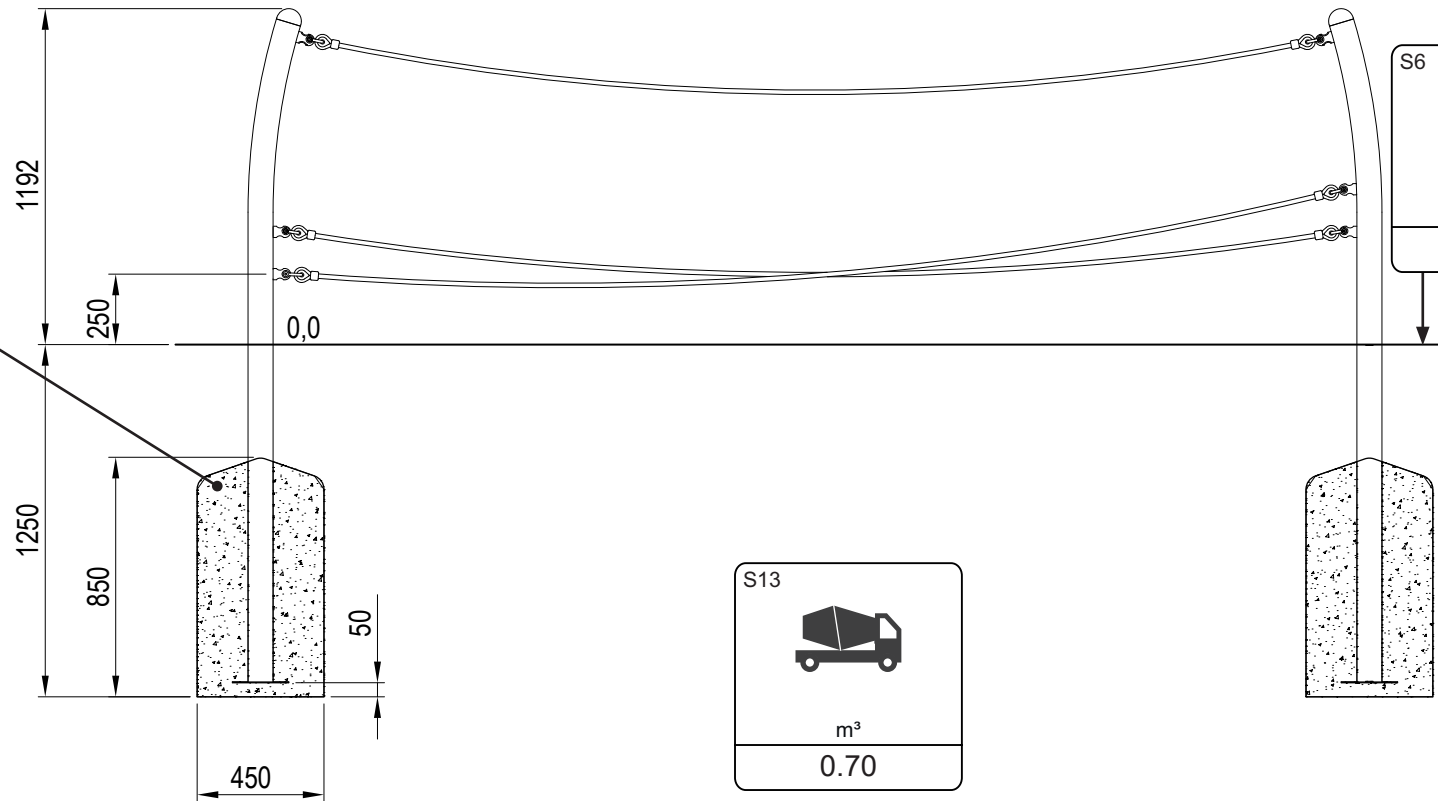

S6



EN1176
0.6m

S13



m³
0.70

